

Naos400 400F1/WR50.PT

Small Poles - Bollard H.600 Emission 360°

Rev. 30/10/2023

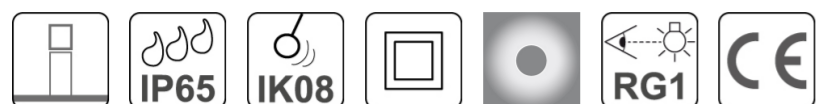

Naos has been developed to cover various residential lighting needs for paths, gardens and avenues. This new bollard is presented with two different optics, the first, with a white diffuser (Naos400), designed to satisfy the need for more lux. The second version (Naos401), on the other hand, with a black reflector, guarantees anti-glare and exceeds all anti-light pollution regulations. Both versions are proposed with powers of 14W and 20W.

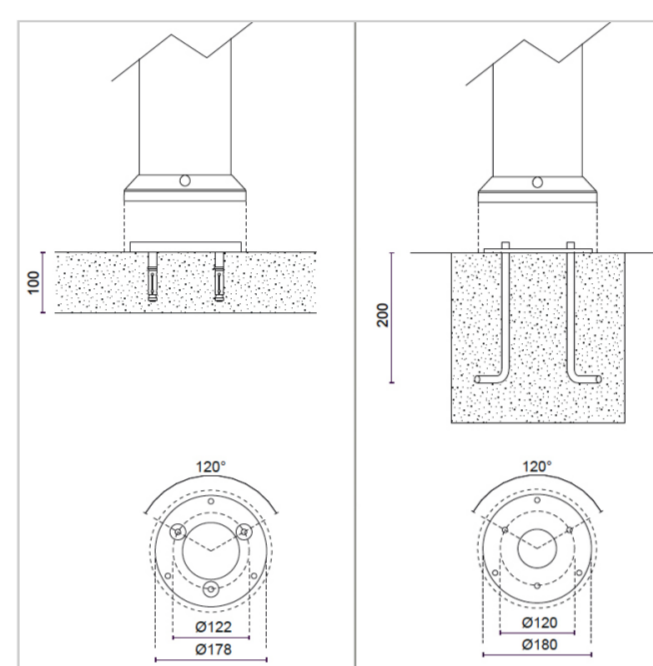
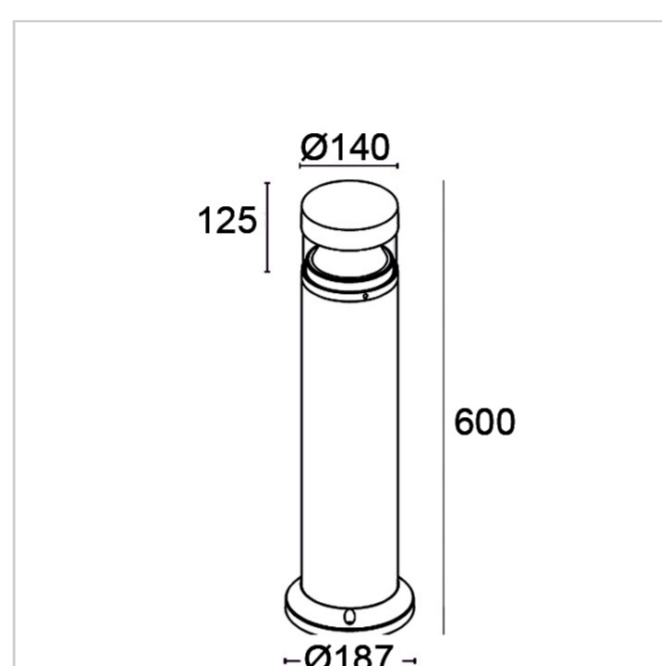

PHOTOMETRICAL DATA

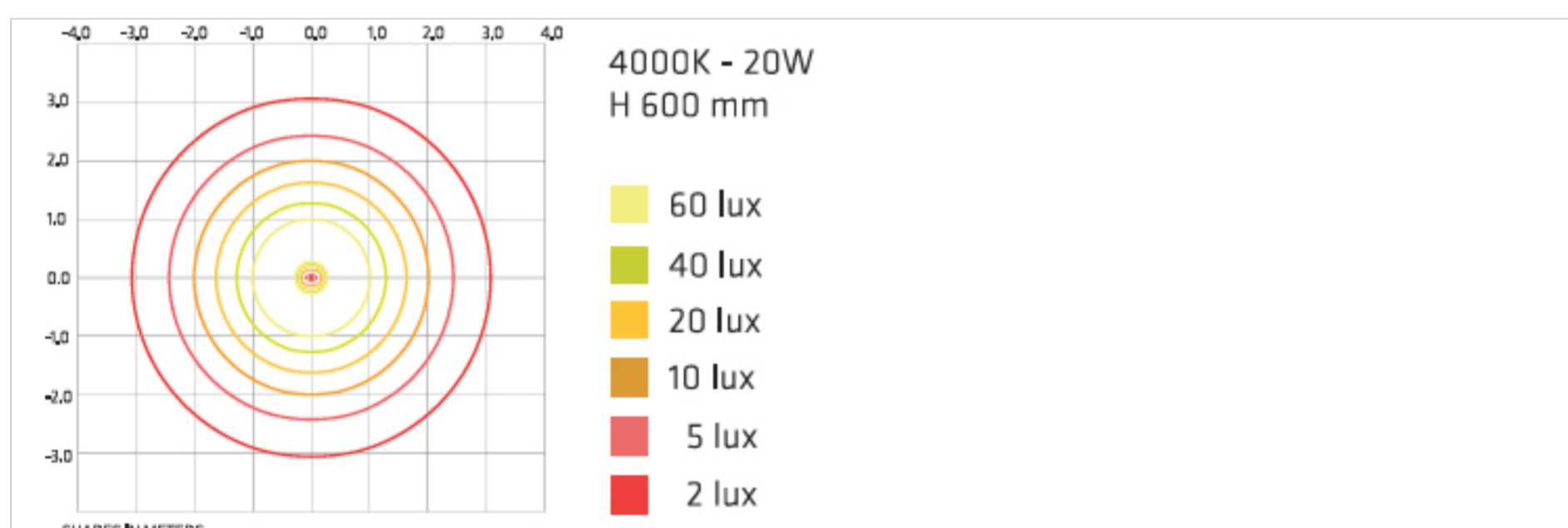

FIXTURE SPECIFICATIONS

ASSEMBLY / USAGE

Ground installation

PROTECTION

IP 65 - IK 08

BODY

Pole: Extruded aluminium alloy - Body/Base: Die-cast aluminium alloy

SCREEN

Transparent Polycarbonate

SEALS

Closed-cell EPDM rubber

SCREWS

Stainless steel A2

PAINT / FINISHING

Anti-corrosive UV stabilised polyester powder

SIZES

H 600 x Ø 140 x Ø base 187

ELECTRICAL SPECIFICATIONS

POWER SUPPLY

220-240Vac 50/60Hz

DRIVER

Built-in

DRIVER CURRENT

500mA

DIMMER SYSTEM

Phase cut dimmable

SPECIFIC WIRING

Inclusa/Included

WIRING

Included

POWER MODULE LED

18W

ABSORBED POWER

20W

SOURCE

LED

SOURCE FLUX

2700 lm

FIXTURE SOURCE

1400 lm

APPARENT EFFICIENCY

52 %

INSULATION CLASS

II

OVERVOLTAGE PROTECTION

2kV-4kV

CCT LED

3000K

CRI

>80

LIFE TIME TM-21

L80B10 50000h

PHOTOBIOLOGICAL RISK

RG1

OPTIK DISTRIBUTION

White reflector

BEAM OPENING

Indirect/Diffuse 360°

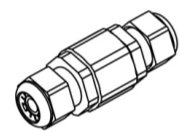
COLORS**ACCESSORIES**

MOR683P/2V Connector IP68 2Way/3Poles. Maximum section 3x2.5mm²
L82xØ28



E.TRA.581 Ultra compact type 2+3 hard wired surge protector. CLII - IP67. Disconnection signaling by indicator. AC disconnection in case of end of life.
L37xW30xH30
L37xW30xH30

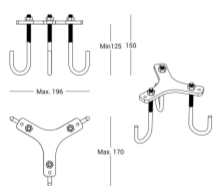

KIT.005 Ground anchoring system with anchor bolts and centring plate